

How to connect 3 TFminis on Arduino DUE via UART

Version:v1.0

Updated date:2018.8.14

Mincy Zhao

1. Introduction

This is about how to connect 3 TFminis on Arduino DUE via TTL UART. The Arduino DUE comes with four hardware UART interfaces. We use three of them to connect one TFmini separately. Another connects to the computer for viewing data.

2. Materials

- TFmini × 3;
- Arduino DUE × 1;
- DuPont wire;
- PC (Windows);
- Arduino IDE;



Benewake



3. Connection

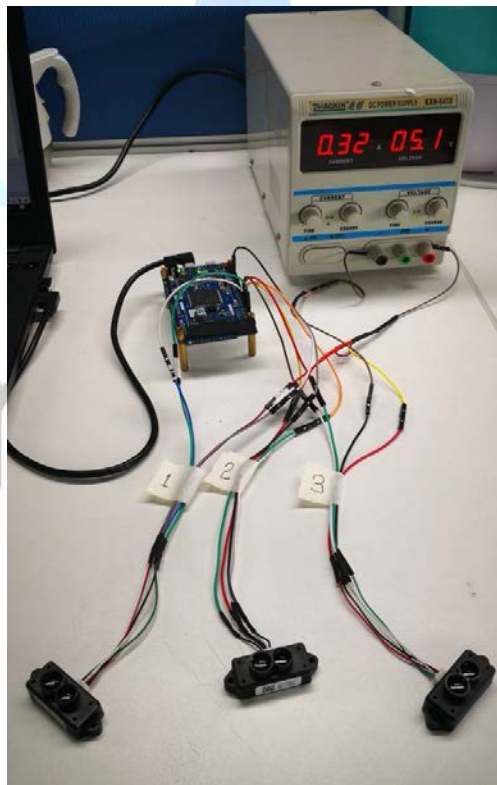
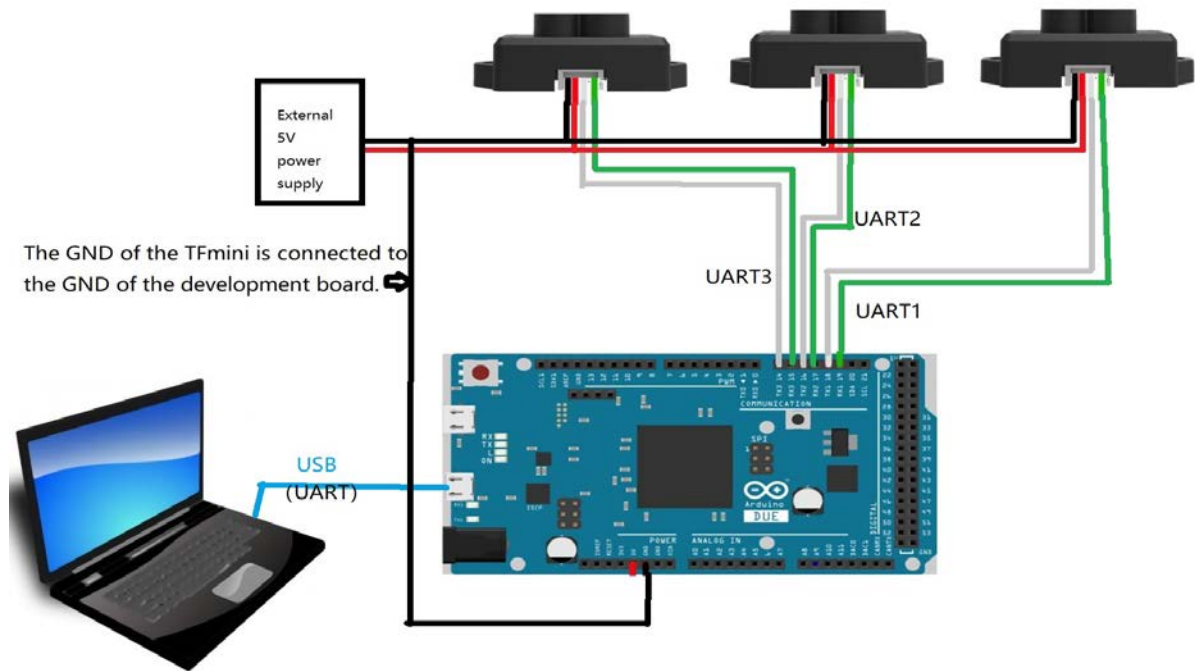

- Because the 5V output capability on the DUE board is not enough to power three TFminis. So all TFminis use an external 5V power supply.



4. Arduino IDE

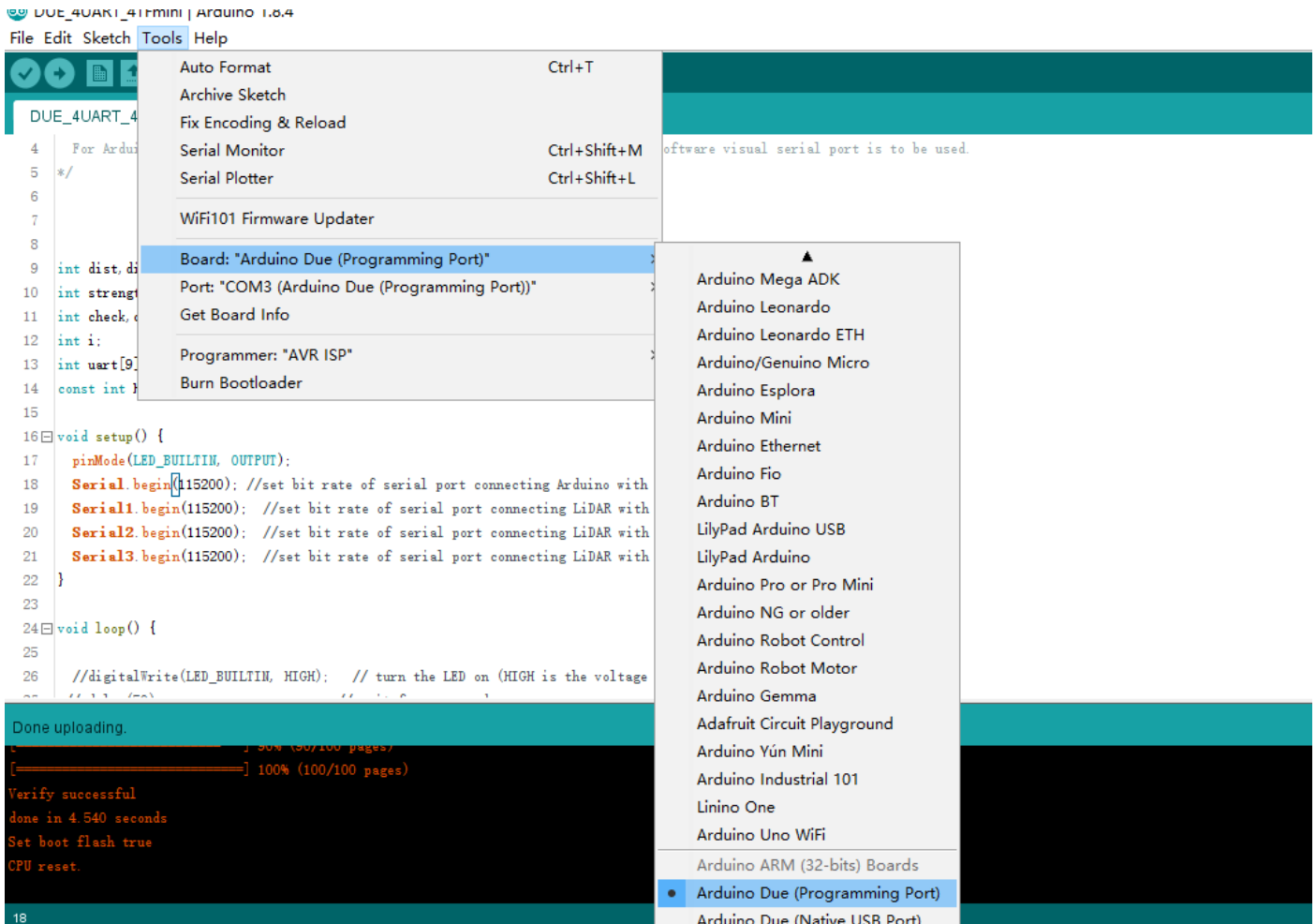

5. Coding



```

/*
Multiple TFminis ---- Arduino DUE ---- UART

```

This is a sample code for connecting 3TFminis to Arduino DUE board via UART, each TFmini use one UART.

For details, refer to Product Specifications.

The Arduino DUE comes with four hardware UART interfaces. We use three of them to connect one TFmini separately.

Another connects to the computer for viewing data.

This is just to provide testing, not my company's official product. Do not use for commercial purposes

In principle, we do not provide technical support for this code.

Author:Mincy Zhao

Update date:2018.08.14



```
*/  
  
int dist,dist2,dist3; //actual distance measurements of LiDAR  
int strength,strength2,strength3; //signal strength of LiDAR  
unsigned char check,check2,check3; //save check value  
int i;  
unsigned char uart[9],uart2[9],uart3[9]; //save data measured by LiDAR  
const int HEADER=0x59; //frame header of data package  
int rec_debug_state = 0x01,rec_debug_state2 = 0x01,rec_debug_state3 = 0x01;//receive state for frame  
//unsigned char rec_flag = 0,rec_flag2 = 0,rec_flag3 = 0;  
  
void setup() {  
  Serial.begin(115200); //set bit rate of serial port connecting Arduino with computer  
  Serial1.begin(115200); //set bit rate of serial port connecting LiDAR1 with Arduino  
  Serial2.begin(115200); //set bit rate of serial port connecting LiDAR2 with Arduino  
  Serial3.begin(115200); //set bit rate of serial port connecting LiDAR3 with Arduino  
}  
  
void loop() {  
  Get_Lidar1_data();//if this channel is not be used, comment out this line  
  Get_Lidar2_data();//if this channel is not be used, comment out this line  
  Get_Lidar3_data();//if this channel is not be used, comment out this line  
}  
  
void Get_Lidar1_data(){  
  if (Serial1.available()) { //check if serial port has data input  
  
    if(rec_debug_state == 0x01){//the first byte  
      uart[0]=Serial1.read();  
      if(uart[0] == 0x59){  
        check = uart[0];  
        rec_debug_state = 0x02;  
      }  
    }  
  
    else if(rec_debug_state == 0x02){//the second byte  
      uart[1]=Serial1.read();  
      if(uart[1] == 0x59){  
        check += uart[1];  
        rec_debug_state = 0x03;  
      }  
      else{  
        rec_debug_state = 0x01;  
      }  
    }  
  }  
}
```



```
else if(rec_debug_state == 0x03){
    uart[2]=Serial1.read();
    check += uart[2];
    rec_debug_state = 0x04;
}

else if(rec_debug_state == 0x04){
    uart[3]=Serial1.read();
    check += uart[3];
    rec_debug_state = 0x05;
}

else if(rec_debug_state == 0x05){
    uart[4]=Serial1.read();
    check += uart[4];
    rec_debug_state = 0x06;
}

else if(rec_debug_state == 0x06){
    uart[5]=Serial1.read();
    check += uart[5];
    rec_debug_state = 0x07;
}

else if(rec_debug_state == 0x07){
    uart[6]=Serial1.read();
    check += uart[6];
    rec_debug_state = 0x08;
}

else if(rec_debug_state == 0x08){
    uart[7]=Serial1.read();
    check += uart[7];
    rec_debug_state = 0x09;
}

else if(rec_debug_state == 0x09){
    uart[8]=Serial1.read();
    if(uart[8] == check){
        dist = uart[2] + uart[3]*256;//the distance
        strength = uart[4] + uart[5]*256;//the strength
        Serial.print("dist = ");
        Serial.print(dist); //output measure distance value of LiDAR
        Serial.print("\t");
    }
}
```



```
Serial.print("strength = ");  
Serial.print(strength); //output signal strength value  
Serial.print('\n');  
}  
rec_debug_state = 0x01;  
}  
}  
}
```

```
void Get_Lidar2_data(){  
if (Serial2.available()) { //check if serial port has data input
```

```
if(rec_debug_state2 == 0x01){//  
uart2[0]=Serial2.read();  
if(uart2[0] == 0x59){  
check2 = uart2[0];  
rec_debug_state2 = 0x02;  
}  
}
```

```
else if(rec_debug_state2 == 0x02){//  
uart2[1]=Serial2.read();  
if(uart2[1] == 0x59){  
check2 += uart2[1];  
rec_debug_state2 = 0x03;  
}  
else{  
rec_debug_state2 = 0x01;  
}  
}
```

```
else if(rec_debug_state2 == 0x03){  
uart2[2]=Serial2.read();  
check2 += uart2[2];  
rec_debug_state2 = 0x04;  
}
```

```
else if(rec_debug_state2 == 0x04){  
uart2[3]=Serial2.read();  
check2 += uart2[3];  
rec_debug_state2 = 0x05;  
}
```

```
else if(rec_debug_state2 == 0x05){  
uart2[4]=Serial2.read();
```



```
        check2 += uart2[4];
        rec_debug_state2 = 0x06;
    }

    else if(rec_debug_state2 == 0x06){
        uart2[5]=Serial2.read();
        check2 += uart2[5];
        rec_debug_state2 = 0x07;
    }

    else if(rec_debug_state2 == 0x07){
        uart2[6]=Serial2.read();
        check2 += uart2[6];
        rec_debug_state2 = 0x08;
    }

    else if(rec_debug_state2 == 0x08){
        uart2[7]=Serial2.read();
        check2 += uart2[7];
        rec_debug_state2 = 0x09;
    }

    else if(rec_debug_state2 == 0x09){
        uart2[8]=Serial2.read();
        if(uart2[8] == check2){
            dist2 = uart2[2] + uart2[3]*256;//the distance
            strength2 = uart2[4] + uart2[5]*256;//the strength
            Serial.print("                dist2 = ");
            Serial.print(dist2); //output measure distance value of LiDAR
            Serial.print("\t");
            Serial.print("strength2 = ");
            Serial.print(strength2); //output signal strength value
            Serial.print("\n");
        }
        rec_debug_state2 = 0x01;
    }
}
}

void Get_Lidar3_data(){
    if (Serial3.available()) { //check if serial port has data input

        if(rec_debug_state3 == 0x01){//
            uart3[0]=Serial3.read();
            if(uart3[0] == 0x59){
```



```
        check3 = uart3[0];
        rec_debug_state3 = 0x02;
    }
}

else if(rec_debug_state3 == 0x02){//
    uart3[1]=Serial3.read();
    if(uart3[1] == 0x59){
        check3 += uart3[1];
        rec_debug_state3 = 0x03;
    }
    else{
        rec_debug_state3 = 0x01;
    }
}

else if(rec_debug_state3 == 0x03){
    uart3[2]=Serial3.read();
    check3 += uart3[2];
    rec_debug_state3 = 0x04;
}

else if(rec_debug_state3 == 0x04){
    uart[3]=Serial3.read();
    check3 += uart3[3];
    rec_debug_state3 = 0x05;
}

else if(rec_debug_state3 == 0x05){
    uart3[4]=Serial3.read();
    check3 += uart3[4];
    rec_debug_state3 = 0x06;
}

else if(rec_debug_state3 == 0x06){
    uart3[5]=Serial3.read();
    check3 += uart3[5];
    rec_debug_state3 = 0x07;
}

else if(rec_debug_state3 == 0x07){
    uart3[6]=Serial3.read();
    check3 += uart3[6];
    rec_debug_state3 = 0x08;
}
}
```





```
else if(rec_debug_state3 == 0x08){
    uart3[7]=Serial3.read();
    check3 += uart3[7];
    rec_debug_state3 = 0x09;
}

else if(rec_debug_state3 == 0x09){
    uart3[8]=Serial3.read();
    if(uart3[8] == check3){
        dist3 = uart3[2] + uart3[3]*256;//the distance
        strength3 = uart3[4] + uart3[5]*256;//the strength
        Serial.print("
dist3 = ");
        Serial.print(dist3); //output measure distance value of LiDAR
        Serial.print('\t');
        Serial.print("strength3 = ");
        Serial.print(strength3); //output signal strength value
        Serial.print('\n');
    }
    rec_debug_state3 = 0x01;
}
}
```

Benewake

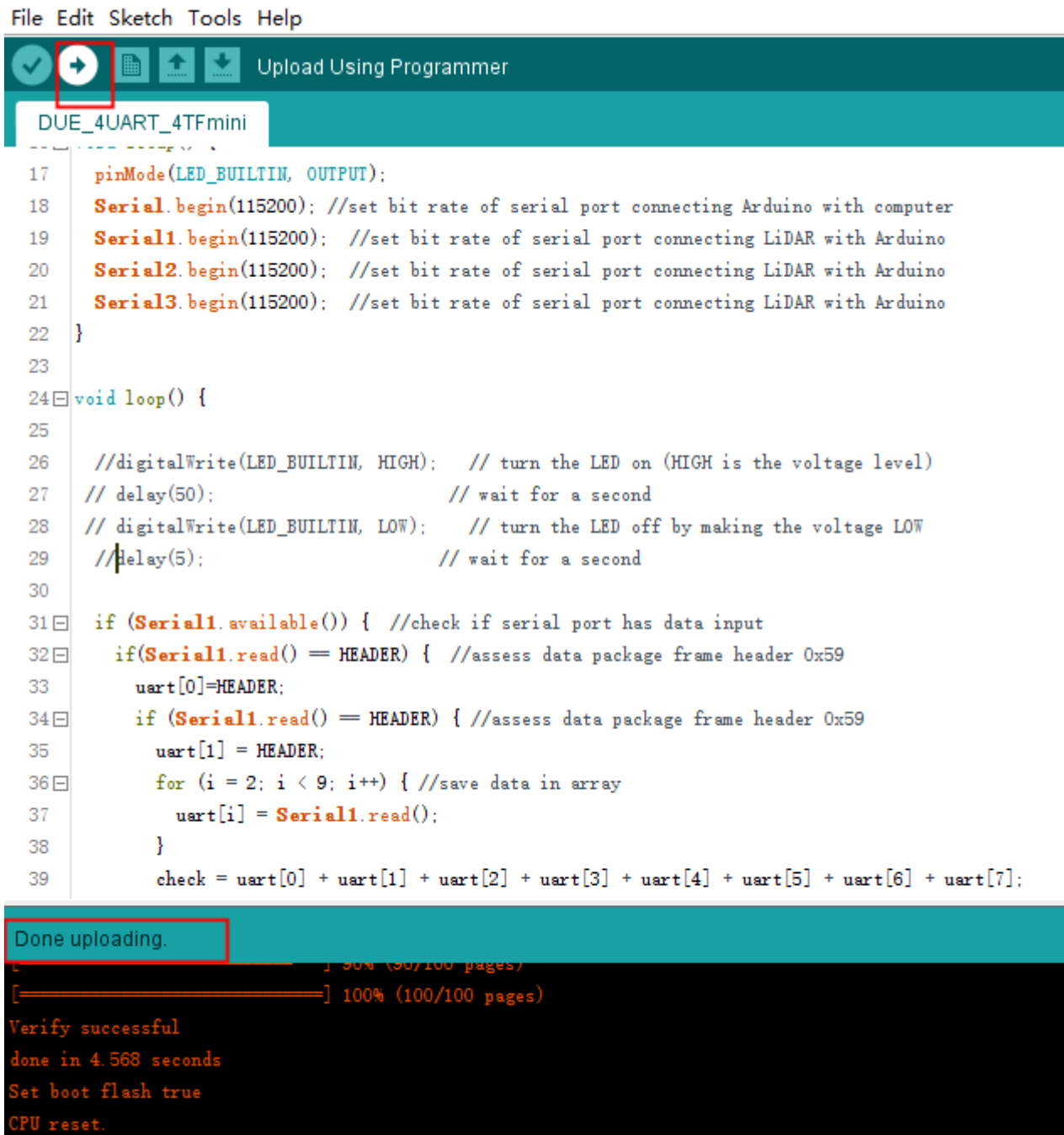

6. Verify & upload



```
File Edit Sketch Tools Help
Upload Using Programmer
DUE_4UART_4TFmini
17 pinMode(LED_BUILTIN, OUTPUT);
18 Serial.begin(115200); //set bit rate of serial port connecting Arduino with computer
19 Serial1.begin(115200); //set bit rate of serial port connecting LiDAR with Arduino
20 Serial2.begin(115200); //set bit rate of serial port connecting LiDAR with Arduino
21 Serial3.begin(115200); //set bit rate of serial port connecting LiDAR with Arduino
22 }
23
24 void loop() {
25
26 //digitalWrite(LED_BUILTIN, HIGH); // turn the LED on (HIGH is the voltage level)
27 // delay(50); // wait for a second
28 // digitalWrite(LED_BUILTIN, LOW); // turn the LED off by making the voltage LOW
29 //delay(5); // wait for a second
30
31 if (Serial1.available()) { //check if serial port has data input
32 if(Serial1.read() == HEADER) { //assess data package frame header 0x59
33 uart[0]=HEADER;
34 if (Serial1.read() == HEADER) { //assess data package frame header 0x59
35 uart[1] = HEADER;
36 for (i = 2; i < 9; i++) { //save data in array
37 uart[i] = Serial1.read();
38 }
39 check = uart[0] + uart[1] + uart[2] + uart[3] + uart[4] + uart[5] + uart[6] + uart[7];
}
Done uploading.
[=====] 100% (100/100 pages)
Verify successful
done in 4.568 seconds
Set boot flash true
CPU reset.
```



7. Viewing

- Use Serial Monitor to view the data.

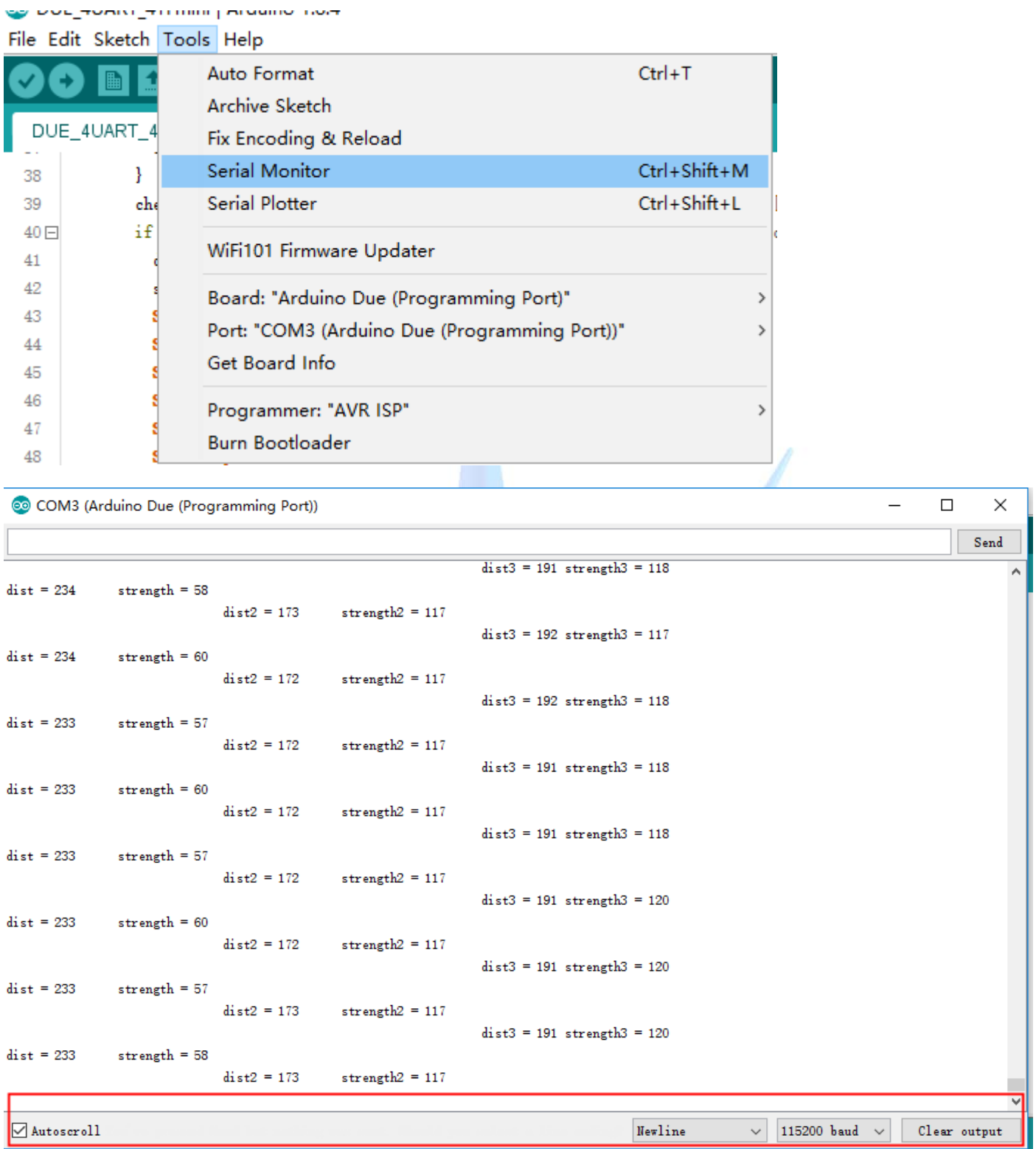

The screenshot shows the Arduino IDE interface. The 'Tools' menu is open, and 'Serial Monitor' is selected. The Serial Monitor window is open, displaying the following data:

```

dist = 234    strength = 58                                dist3 = 191 strength3 = 118
                                dist2 = 173    strength2 = 117
dist = 234    strength = 60                                dist3 = 192 strength3 = 117
                                dist2 = 172    strength2 = 117
dist = 233    strength = 57                                dist3 = 192 strength3 = 118
                                dist2 = 172    strength2 = 117
dist = 233    strength = 60                                dist3 = 191 strength3 = 118
                                dist2 = 172    strength2 = 117
dist = 233    strength = 57                                dist3 = 191 strength3 = 118
                                dist2 = 172    strength2 = 117
dist = 233    strength = 60                                dist3 = 191 strength3 = 120
                                dist2 = 172    strength2 = 117
dist = 233    strength = 57                                dist3 = 191 strength3 = 120
                                dist2 = 173    strength2 = 117
dist = 233    strength = 58                                dist3 = 191 strength3 = 120
                                dist2 = 173    strength2 = 117
  
```

The Serial Monitor window also shows the following settings:

- Autoscroll
- Newline
- 115200 baud
- Clear output

